

Agents :



Evaporative Air Cooler

Manual Instruction



COLENT MARKETING PHILIPPINES, INC. (CMPI)
TEL.: (632)442-3866, 412-6155, 448-7674, 442-3856
MOBILE: 0923-5345681, 0917-3079188
EMAIL: sales_mktg@colentco.com
WEB: www.colentco.com

We reserve all modification rights of this manual.
manual content are change without prior notice.

**Single- phase with 3 speeds
movable Axial fan
Use in :
KLF-07B**

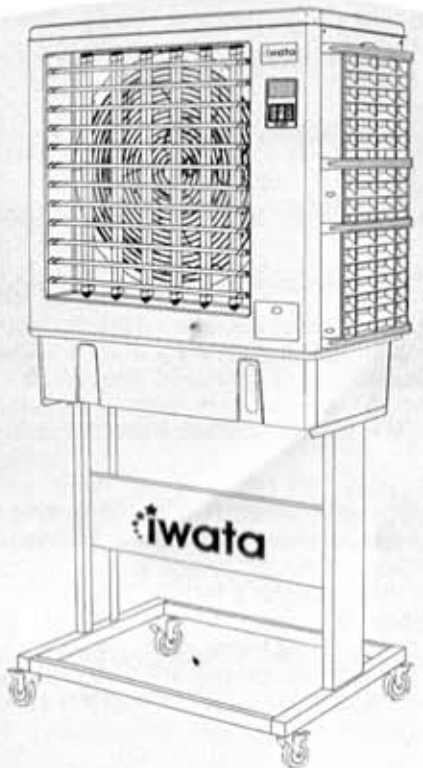

Please read this instruction manual carefully before using

Please read this instruction manual carefully before using !

Content

I 、 Safety Instruction	1
II 、 Product Introduction	1
III 、 Parameter Table	2
IV 、 Scope of Application	2
V 、 Conditions of Using	2
VI 、 Structure of Machine	3
VII 、 Package Content	3
VIII 、 Matters Need Attention	4
IX 、 Schematic Diagram of Circuit	6
X 、 Installation	6
XI 、 Control Panel Introduction	7
XII 、 Operation Instruction	7
XIII 、 Cleaning and Maintenance	8
XIV 、 General Fault and Solution	9

Evaporative air cooler

I 、 Safety Instruction

1. Please keep the sundries and hands away from this machine air outlet. Once the object touched the fan in high speed operation, it is dangerous to the people and it will damage the fan.
2. Please do not climb up on this machine or place anything on the machine. Please prevent the children touch this machine.
3. The area where is this machine can blow directly, please do not place the burners, otherwise it may cause carbon monoxide poisoning.
4. Please do not make bold to dismount and refit this machine. The inappropriate dismounting and refitting may cause water leakage, fire disaster and electric shock.
5. Please do not install this machine in some place where is inflammable and explosive dangerous gas around this machine, it easy to occur explosive accident.
6. If this machine is not used for a long period of time, turn off the water supply and drain all the water out of the water container, and then keep this machine operative in wind supply function, so that the cooling pads become complete dry.
7. This machine must connect with the earth wire reliably, or it may cause electric shock or fire disaster.

II 、 Product Introduction

The advantage of air cooler:

Energy saving: air cooler is saving 80% energy than the traditional air conditioner .

Environmental protection: The cooling air of air cooler is produced from water evaporation, it does not discharge any harmful substance.

High effective: Optimal use the natural cold energy, manufacture the best cooling effective from the lest electric power.

Air cooler is a new generation which was developed according to the climate from north latitude 53 degree to south latitude 34 degree ,it is suitable for the majority of the worldwide. The fan of product use the new generation which is high speed, large airflow and excellent ventilation effect.

The cooling principle of operation is the fresh air flow let the moisture vaporization and absorbing a lot of heat in a very short period of time. This is the new green energy-saving product. When this machine is working, it pumps water to the water dispersion dish from the water container and make the cooling pads soaked completely. The axial fan moves in a high speed ,that let a large number of fresh air cross the cooling pads in a high speed, thus it make the water vaporization, at the same time it also manufacture a great quantity of oxygen ions. The process of ventilation and cooling is sending the oxygen-rich fresh air indoor, discharging the turbid air outdoor through the opening windows and doors. The airflow keeps repeating recycle again and again. The temperature will drop quickly and the air quality will get improved a lot.

Evaporative air cooler

III、Parameter Table

Model	KLF-07B
Airflow	6000m ³ /h
Voltage/Frequently	220V/60Hz
Current	0.96A
Power	0.25kW
Motor protection grade	IPX4
Type of Fan	Axial /3 speeds
Water Container	40L
Machine Size (mm)	910x480x1750
Net Weight	41.5kg
Rang of Air Supply (m)	12x3
Air Outlet Dimension(mm)	600×640
Lowest Noise	65dB
Water Consumption	3~6L/h
Machine protection grade	IPX4

IV、Scope of Application

Air cooler has a lot of excellent advantages like cooling, humidification, purification, ventilation, saving energy. This product suitable for the place is open and ventilation .

1.Processing industry: electronics, electroplate, shoemaking, textile printing, plastic, garment, packing, foodstuff.

2.Manufacturing industry: spinning, machinery, ceramics, fine chemistry, metallurgy, glass, hardware, leather.

3.Hospital, clinic, school, waiting room, cyber cafe, store, supermarket, washing room.

4.Public: kitchen, food market, big entertainment center, underground parking, bus station.

5.Farm: green house, flower, poultry, livestock.

6.If some place have strict humidity require, the equipments should depend on the engineering design.

V、Conditions of Using

1.Ambient temperature: 25℃~45℃

2.Relative humidity: ≤90%

3.Water supply should make softening treatment.

0℃ < temperature of water supply < 45℃.

Pressure of water supply: 0.15~0.6MPa

4.Deviation of voltage can not more than ±10% of rated voltage;

5.No corrosive gas;

6.No inflammable and explosive gas or dust.

Evaporative air cooler

VI、Structure of Machine

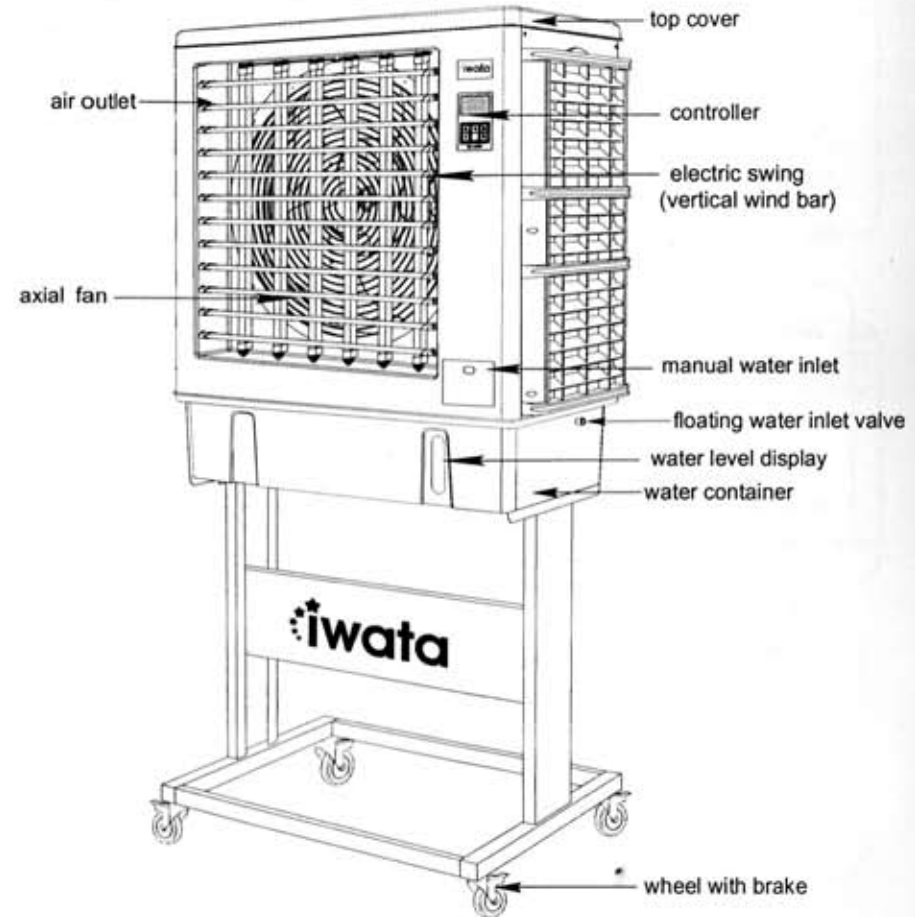

VII、Package Content

No.	Name	Quantity
1	Air cooler	1
2	Product manual	1
3	Warranty card	1

Evaporative air cooler

VIII. Matters Need Attention

Please review and follow all instructions below to prevent damage asset and people safety.

⚠ This sign means please be careful— “Reminding”

⊘ This sign means not be allow to do— “Ban”

❗ This sign means please make sure to do— “Enforcement”

Only the qualified servicemen can maintain or refit this machine!



Not allow to disconnect this machine

It may cause fire disaster or unusual movement to harm the people.

Use only AC220V-240V ± 10% Voltage.



Ban

If the voltage is not AC220-240V it may cause damage or electrical shock.

Please use the rated current more than 5A socket independently.

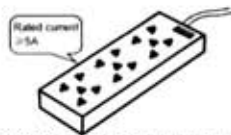

If share the socket with other appliance, it may cause socket become heat, even on fire.

This machine should use single phase two-stage with earth wire socket, and should make sure it is connect with the earth wire reliably! If not connect with the earth wire, it may cause the cabinet and metal parts with electrostatic induction.



Ensure connect with earth wire

If the fault and electric leakage happened, it may cause the electric shock.

Please grasp the plug pull out the power supply plug, do not grasp the power supply wire! Not allow operate with wet hands.

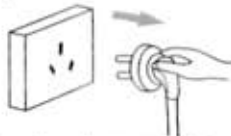

If in a fault operation, it easy to cause electric shock or on fire.

Please do not damage, curve, pull, twist or tie the power supply wire. Please do not place any heavy object on the power supply wire. If the electric leakage protection was damage, the power supply wire was burn-in, to a knot, plug was damage, please cease this product immediately.



Ban



If in a fault operation, it is easy to cause the fire disaster and electric shock

Evaporative air cooler

When cleaning the water container and Pads or not use this machine for a long period of time please remove the plug from the socket.

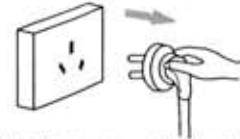

If in a fault operation, it may cause the electric shock to harm the people

If the power supply wire is damage, please contact a professional to repair who is specified by the manufacturer.



If in a fault operation, it may cause some negative effect.

Please keep use water supply pressure of 0.15-0.6MPa. Please keep the water temperature lower than 45°C.



Ban



If the water supply pressure and temperature are too high, it may cause the cooling pads melt, plastic parts transformation. It may influence the performance of machine.

Please not inset any object into the air inlet and air outlet. Please keep the children away from the operating machine and prevent the child use their hands or objects inset the machine protection net.



Ban

The fan is running in high speed, if the child put their hands inset to the air inlet or outlet is very danger.

⚠ This machine is suitable for operation indoor.

⊘ It not allow use this machine in some place with inflammable and explosive gas, prevent direct sunshine on this machine.

⚠ Do not place the machine on a slope it may cause the machine to topple and damage the equipment inside.

⚠ Please do not place air inlet of this machine near the wall or window curtain, otherwise it may blocking the air flow, influence the effective cooling and ventilation.

⚠ When the water container is full, please do not place this machine on a slope or crash it. If want to move it, please push it on flank to prevent the water spill.

⚠ Only the qualified professional person can take charge the maintain of this machine.

⚠ If the supply cord is damaged, it must be replaced by the manufacturer, its service agent or similarly qualified persons in order to avoid a hazard.

⊘ All parts of this machine can not discard casually, not allow throw them into dustbin.

Evaporative air cooler

IX、Schematic diagram of circuit

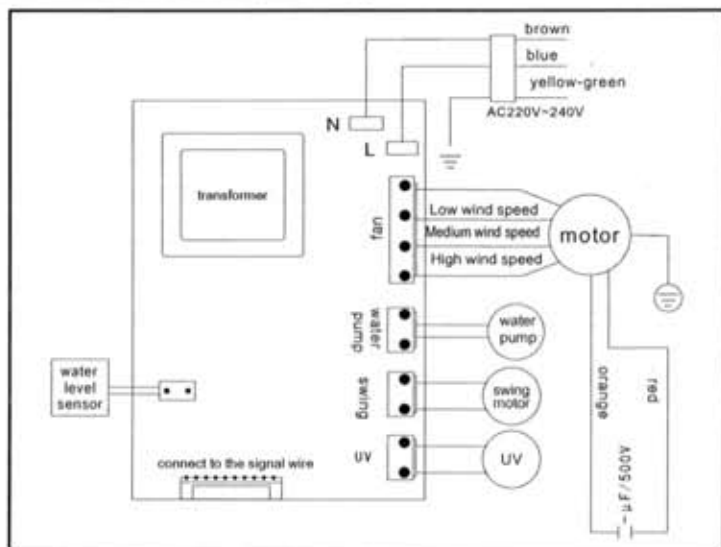

Evaporative air cooler

XI、Control panel introduction



LED Light definition LED

- "H" "High wind speed"
- "M" "Medium wind speed"
- "L" "Low wind speed"
- "1h 2h 4h 8h" "Time setting"
- "❄️" "Cooling"
- "🌀" "Wind swing"
- "UV" "UV"
- "⚡" "Water shortage"

Button definition

- "🌀" "Wind speed"
- "❄️" "Cooling"
- "🕒" "Time setting"
- "🌀" "Wind swing"
- "⚡" "Signal"
- "⏻" "ON/OFF"

XII、Operation instruction

1. Inset the plug into the socket, press the reset button of the electric leakage protection device. Power supply on after the circuit board electrify, power supply normal work. (Electric leakage protection device should press the test button and reset on time, to test the electric leakage protection device if normal work. When it is damage, you should replace a new one.)
2. "On/Off" button: After connected the power supply and press this button, the machine will operate with medium wind speed and swing wind. After the machine operated, then setting the wind speed and wind swing. Turn off the machine means shutdown all the power output.
3. "Cooling" button:
 - 1). Water shortage: press the "wind speed" button, then the fan operation, press the "swing" button to set the wind swing, water pump dose not work, the warning light flicker and warning sounding 15 times, pause 30 seconds, then continue warning light flicker and warning sounding 15 times, finally the warning light keep turn on.
 - 2). water enough: Operating the water pump firstly, wind speed light and wind swing light flicker, after 30 seconds, then operating dependent on the wind speed and wind swing setting. after water pump worked 5 minutes, UV Lamp start to disinfect water, the water treatment light on the panel, UV lamp will closed after work 20 minutes (UV lamp is the optional function)
4. "Wind speed" button: adjusting the motor wind speed: high speed medium speed-low speed-high speed...
5. "wind swing" button: control the wind swing turn on and turn off. When the fan closed, the wind swing will be locked.
6. "Time setting" button: setting the working time: 0-1-2-4-8-0 (h)

X、Installation

1. Open the package and take out the air cooler, place it on horizontal floor.
2. Check the parts in the packing case if the same as the package content.
3. Open the cover of water inlet, add the clean tap water, and please pay attention do not let the water level higher then the sign "H" on the water container.
4. Check the power supply if the same as the parameter on the nameplate of this machine.
5. Connect with the power supply, press the "power" button on the control panel, choosing the suitable wind speed, then the air cooler is operating.

Notice:

- Do not pull out the power plug with wet hand to prevent cause dangerous of electric shock.
- Pull out the power plug before moving this machine.
- Inset the plug into the power socket, and keep good connect.
- Please keep the water away from the electric leakage protection device. If it was splashed wet, please clear away the water and check over before continue operation.

Warm prompt: Please keep this product manual and package well after installation for using in future.

Evaporative air cooler

XIII, Cleaning and maintenance

◆Cleaning the cooling pads and dustproof net

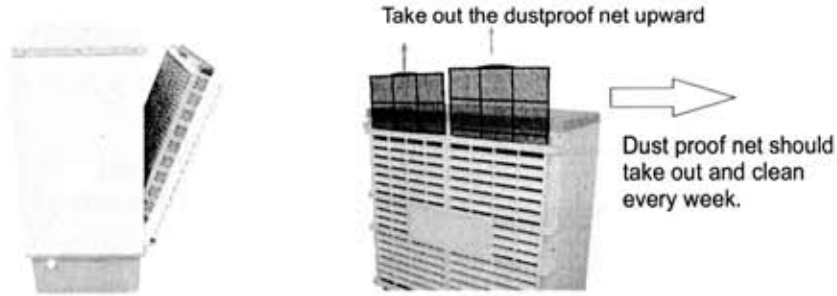

Pull out the power supply power plug, screwing out the screws from the louver by electric drill. Holding the top of louver and pull out (with a bit pull upward), remove the cooling pads kits and wash them by high pressure water gun, until the dirt complete be washed out.

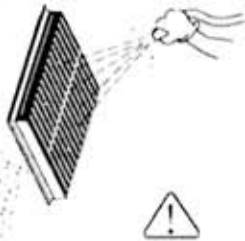

Attention:

When washing the cooling pads do not use too high pressure water, it will damage the pads, and do not use any acid or alkaline detergents to clean the machine.

◆Clean the water container

Method of cleaning:

1. Turn on the drain outlet cap at the bottom of the machine and drain all the water inside.
2. Pull out power supply plug, screwing out the screws from louver and take out the louver.
3. Use soft cloth or soft brush to clean the chassis.
4. Use wet washcloth to clean out the dirt on the water level sensor.
5. Use the washcloth to clean out the dirt on the water pump and dust proof net.
6. Screwing down the drain outlet cap at the bottom of the machine after finish cleaning.

◆Cleaning the machine hull

Using the soft washcloth to clean the machine hull. (Not allow to use the detergent with foaming, volatile solvent or hard brush to clean. The fault method of cleaning will damage the equipment and cause the danger happen.)

Evaporative air cooler

XIV, Ordinary fault and solution

Fault phenomenon	Possible cause	Solution
1. Cannot operate this machine	<ol style="list-style-type: none"> 1. The power supply is not connected 2. "ON/OFF" button does not work 3. phase shortage 4. voltage is too low 	<ol style="list-style-type: none"> 1. Check over the power supply 2. Replace another control panel 3. Check over the phase wire 4. Check over the voltage supply
2. Fuse often break down	<ol style="list-style-type: none"> 1. Water pump break down 2. Drainage pump break down 3. Motor of wind swing break down 	<ol style="list-style-type: none"> 1. Replace another water pump 2. Replace another drainage pump 3. Replace another motor of wind swing
3. Water leakage	<ol style="list-style-type: none"> 1. This machine place not balance 2. Water container leakage 3. Drainage device break down. 4. Water inlet device break down. 5. Water level too high 6. Water distributive pipe device break down 7. Cooling pads dirty 	<ol style="list-style-type: none"> 1. Place this machine to balance 2. Repair the water container 3. Replace the water drainage device 4. Replace the water inlet device 5. Adjust the water float valve position 6. Check over the water distributive pipe device 7. Clean the cooling pads
4. Noise too loud	<ol style="list-style-type: none"> 1. Fan become dirty, transform or break down 2. Motor break down 3. Some sundries block the air inlet or air outlet 	<ol style="list-style-type: none"> 1. Replace another fan 2. Replace another motor 3. Clean out the obstacle
5. No wind supply or airflow too low	<ol style="list-style-type: none"> 1. Cooling pads or dust proof nets are blocking 2. Control panel break down 3. Controller break down 4. Fan does not work 5. Motor phase shortage 	<ol style="list-style-type: none"> 1. Clean or replace the cooling pads or dust proof nets 2. Replace another control panel 3. Replace another controller 4. Check over the motor 5. Check over the phase wire
6. No cooling	<ol style="list-style-type: none"> 1. Water in the container shortage 2. Water level control system 3. Submersible pump break down 4. "cooling" button does not work 5. Controller break down 	<ol style="list-style-type: none"> 1. Add water into water container 2. Repair water level sensor 3. Replace another submersible pump 4. Replace another control panel 5. Replace another controller
7. Water container and dust proof net appear white precipitation	<ol style="list-style-type: none"> 1. The content of mineral substance is too high in water supply 	<ol style="list-style-type: none"> 1. Increase the times of water drainage and have a water soft treatment