



Drum Fan

INSTRUCTION MANUAL

www.colentco.com

Please read the instructions carefully before use.

Assembly scheme

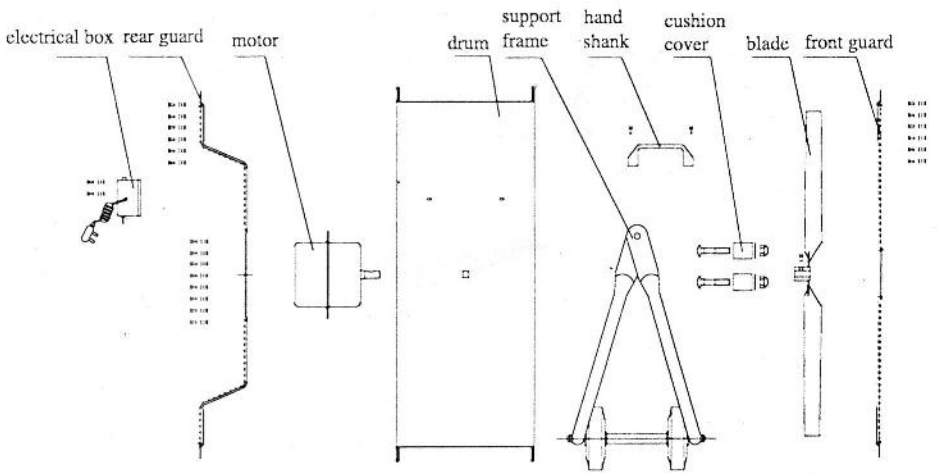

Normal type: TORNADO DRUM-26
TORNADO DRUM-30
Luxury type: TORNADO DRUM-24

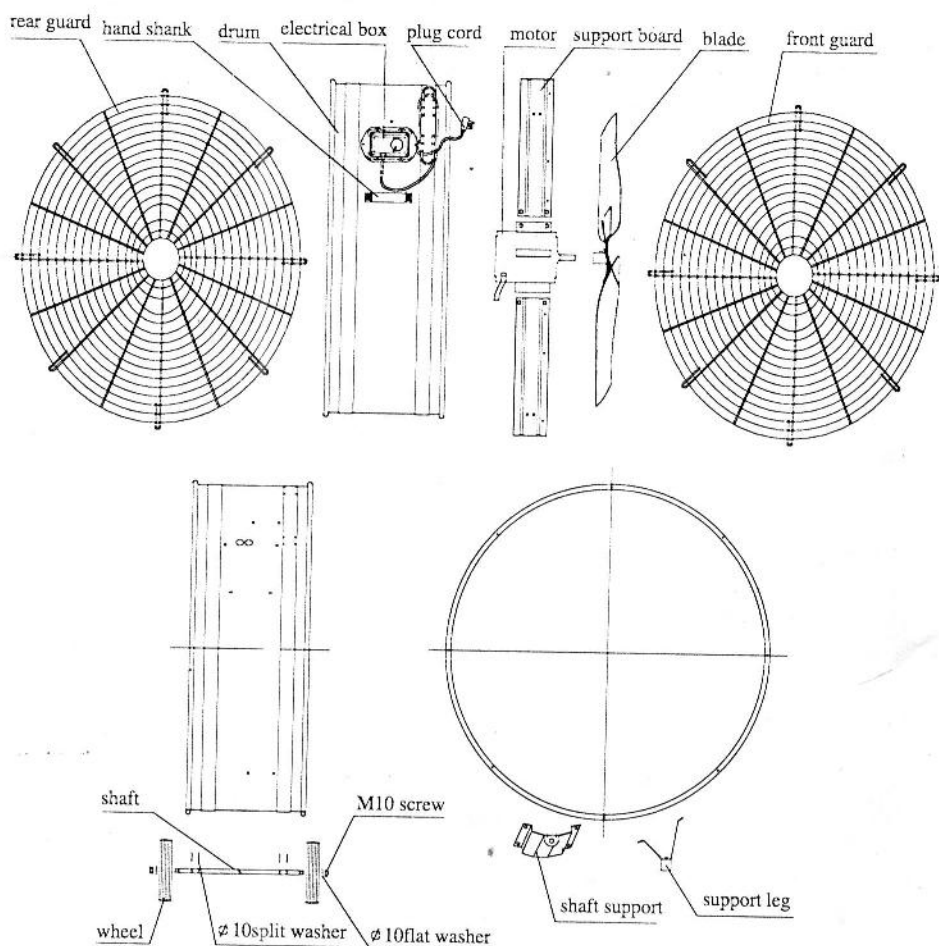

Economical type: TORNADO DRUM-36
TORNADO DRUM-42

Wheel installation for economic type TORNADO DRUM-36, TORNADO DRUM-42:

1. Press the two $\Phi 10$ split washers into the groove at one side of the shaft, and let the shaft get through the shaft support, and then press the two $\Phi 10$ split washers into the groove at the other side of the shaft (For easier installation, put the fan at one side and keep cart round tube upward).
2. Put the shaft into the wheel then add the $\Phi 10$ flat washer at each side and tighten up.
3. Put the bolts and the flat washers into the rubber feet and tighten on the support legs

Cautions

1. Don't insert hands or any objects into the machine's guard.
2. Don't put the machine close to curtain.
3. Don't put the fan on uneven place.
4. Children, elders and weak people can't stand in front of the machine for a long time.
5. Type Y attachment - Damaged supply cords to be replaced by the manufacturer, service agent or similarly qualified person to avoid hazard.
6. Please cut off the power and send the machine to qualified technician to repair it if the running machine emit unusual noise, smoke or machine's blade can not run.
7. Those who are not qualified electricians should not dissemble, repair or rebuild the fan.
8. This appliance is not intended to use by persons (including children) with reduced physical, sensory or mental capabilities, or lack of experience and knowledge, unless they have been given supervision or instruction concerning use of the appliance by a person responsible for their safety. Children should be supervised to ensure that they do not play with the appliance.

Maintenance

1. In order to keep the machine durable, you should clean it timely.
2. Please cut off the power before cleaning and remove the front guard and blade.
Clean the machine with soft cloth (Please don't use gasoline or other corrosive liquid). Please dry the guard and blade with dry cloth, then install the machine.
3. Please don't let water flow into the motor and wet electric elements during cleaning, and also don't press / bend the blade or change the blades' pitch angle.
4. Please clean the machine and seal the whole machine with plastic bag before long time storage of the machine .

Specifications are subject to alter without prior notice due to continuous product improvement.

Thank you very much for selecting our product. Please read the user manual carefully before use for safety and product reliability. Please keep this manual handy for reference.

Features

1. High performance heavy duty motor
2. Enclosed or open motor for selection
3. Designed blade pitch angle to give high air velocity
4. Adjustable tilting angle with U-tube base OR fixed angle design.
5. Equipped with portable castor and wheels
6. Speed control : 2-speed / 3-speed
7. Built-in thermal protector for safety operation and durability
8. Ideal for cooling and air circulation in factories, warehouses, garage, mining industries, and other public places

Operating instructions

1. The power source voltage and frequency should be the same as the rating label specified.
2. Don't use it in corrosive and humid surroundings.
3. Don't use this fan in places where temperature is over 40 °C and the altitude is higher than 1,000 meters.
4. When socket is used in power supply, the socket should meet the IEC335-1 standard; when power supply is from direct charging, a polarity switch should be installed with contact gap not less than 3mm on the charging line.
5. Speed adjustment: (1) the normal type drum fan adopt button switch to adjust the speed, and luxury type TORNADO DRUM-24 adopt rotary switch to adjust the speed, they all have three speeds, as showed on the indication panel: 0 = off / 1= low / 2 = medium / 3 = high. The economical type drum fan adopt rotary switch to adjust the speed, they all have two speed, as showed on the indication panel : 0 = off / 1= low / 2 = high.
6. Blowing angle adjustment: the blowing angle of normal type and luxury type TORNADO DRUM-24 drum fan can be adjusted by loosening locknut and making the angle to particular position and then tightening up the locknut again.
7. The drum fan can be easily moved by lifting the hand shank or cart handle.

Wiring Drawing

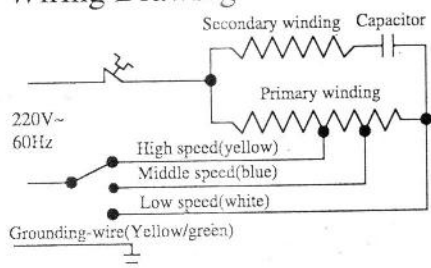

Normal type: TORNADO DRUM-26
 TORNADO DRUM-30
 Luxury type: TORNADO DRUM-24

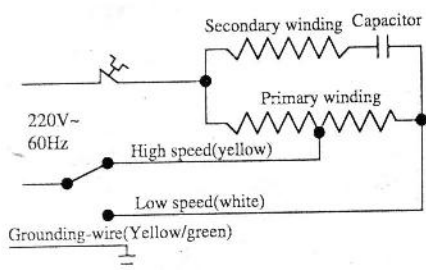

Economical type: TORNADO DRUM-36
 TORNADO DRUM-42

Specification

Parameter \ Item	Stage 1				Stage 2				Stage 3				Dimensions (mm)			
	Speed rpm	Air volume m ³ /min	Noise dB	Power W	Speed rpm	Air volume m ³ /min	Noise dB	Power W	Speed rpm	Air volume m ³ /min	Noise dB	Power W	A	B	C	H
TORNADO DRUM-26	850	143	55	165	950	174	60	190	1100	220	65	230	810	290	740	830
TORNADO DRUM-30	850	214	58	215	950	270	67	240	1100	302	68	280	910	290	840	920
TORNADO DRUM-24	800	174	60	140	920	210	65	150	1050	230	70	160	750	290	670	760
TORNADO DRUM-36	850	350	65	520	1050	460	75	650	/	/	/	/	1060	480	980	1040
TORNADO DRUM-42	850	410	65	620	1050	540	75	750	/	/	/	/	1230	480	1120	1160

Product dimension

Normal type:
TORNADO DRUM-26
TORNADO DRUM-30

Luxury type:
TORNADO DRUM-24

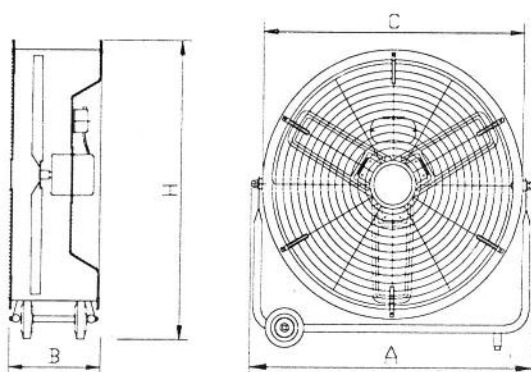

Economical type:
TORNADO DRUM-36
TORNADO DRUM-42

